

# red rooster PNEUMATIC CHAIN HOIST TNC-10TW-AT/4

A comprehensive range of quality pneumatic chain hoists suitable for both industrial and marine environments. Red Rooster pneumatic hoists comply with the European Machinery Directive and are CE marked. Our ISO9001:2008 Quality System is accredited by L.R.Q.A.

### Standard Hoist Features:

- Toku rotary vane motor.
- Robust epicyclic gearbox (grease filled and sealed).
- Failsafe automatic internal disc brake
- Choice of pendant controls or control stations
- Upper and lower limit switches.
- Cast steel housing.
- Variable speed.
- Internal silencing down to 75 dBA
- Alloy safety swivel hooks c/w safety catch.
- Load chain of European manufacture EN818/1-7
- Automatic, adjustable load limiter
- To suit various Flange Profiles
- Anti Tilt Roller & Anti Drop Plates

### Available Options:

- Marine specification – stainless steel chain, marine paint
- Chain collectors (P.V.C., galvanised or stainless steel).
- Travel Limits
- Collision Bumpers
- Air service Units
- Festoon systems
- ATEX Specification Zone 1 & 2
- Articulated Trolley
- Low Headroom Units
- Rack & Pinion Drive
- Special Designs
- Radio Remote Control

	WLL	Chain Falls	Lifting Speed Full Load (m/min)	Lifting Speed Without Load (m/min)	Air Consumption Full Load (l/sec)	Working Pressure	Air Connect	Min. Hose Diam (Bore)	Weight with 3m HOL & Trolley	Weight per metre (HOL)
Hoist	10000kg	2	1.5	2.5	90	6 bar	1 Inch BSP	1 Inch	330kg	11.4kg

	WLL	Flange Size Range 1 Range 2	Travel Speed m/min	Wheel Material	Min Bend Radius	Number of Wheels	Driven Wheels	Max Air Consumption	Hose ID Trolley (Inches)
Trolley	10000kg	110-190 200-300	0-9.5	Steel	2.5	4	2	80 l/sec	1.0

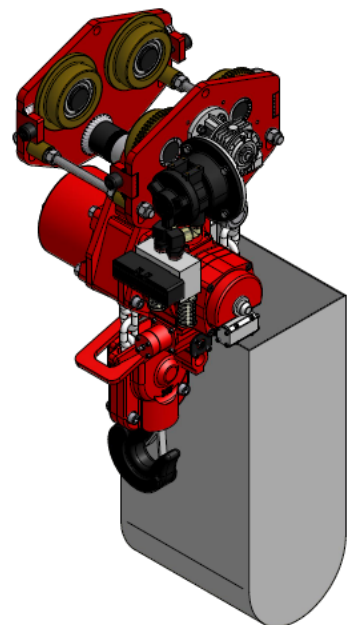
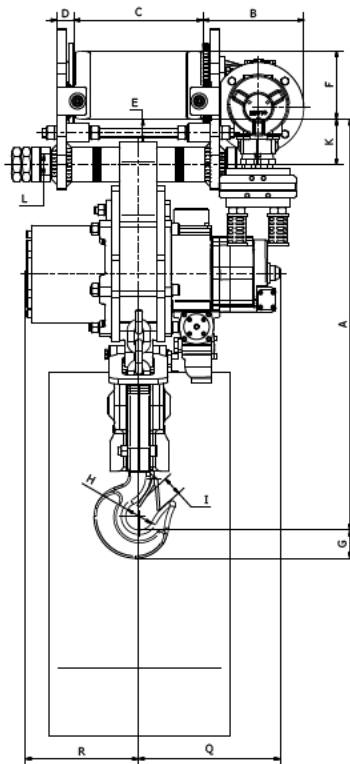
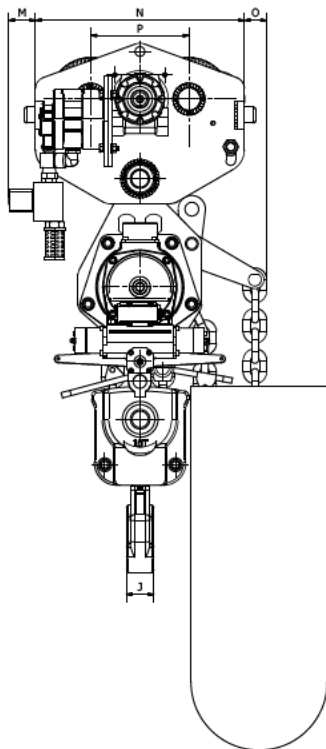

A	B	C	D	E	F∅	G	H	I	J	K	L	M	N	O	P	Q	R
~904	~223	TBC	37	50	150	62	60	40	60	100	45	59	460	49	216	313	249

All measurements are in mm

Drawing For illustration purposes only. Not drawn to scale.