

A comprehensive range of quality pneumatic chain hoists suitable for both industrial and marine environments. Red Rooster pneumatic hoists comply with the European Machinery Directive and are CE marked. Our ISO9001:2008 Quality System is accredited by L.R.Q.A.

Standard Hoist Features:

- Toku rotary vane motor.
- Robust epicyclic gearbox (grease filled and sealed).
- Failsafe automatic internal disc brake
- Choice of pendant controls or control stations
- Upper and lower limit switches.
- Cast steel housing.
- Variable speed.
- Internal silencing down to 75 dBA
- Alloy safety swivel hooks c/w safety catch.
- Load chain of European manufacture EN818/1-7
- Automatic, adjustable load limiter
- To suit various Flange Profiles
- Anti Tilt Roller & Anti Drop Plates

Available Options:

- Marine specification – stainless steel chain, marine paint
- Chain collectors (P.V.C., galvanised or stainless steel).
- Travel Limits
- Collision Bumpers
- Air service Units
- Festoon systems
- ATEX Specification Zone 1 & 2
- Articulated Trolley
- Low Headroom Units
- Rack & Pinion Drive
- Special Designs
- Radio Remote Control

	WLL	Chain Falls	Lifting Speed Full Load (m/min)	Lifting Speed Without Load (m/min)	Air Consumption Full Load (l/sec)	Working Pressure	Air Connect	Min. Hose Diam (Bore)	Weight with 3m HOL & Trolley	Weight per metre (HOL)
Hoist	1000kg	1	6.0	11.3	25	6 bar	½ Inch BSP	½ Inch	61kg	1.1 kg

	WLL	Flange Size Range 1 Range 2	Travel Speed m/min	Wheel Material	Min Bend Radius	Number of Wheels	Driven Wheels	Max Air Consumption	Hose ID Trolley (Inches)
Trolley	1000kg	56-170 171-300	0-9.5	Steel	1.5	4	2	25 l/sec	0.75

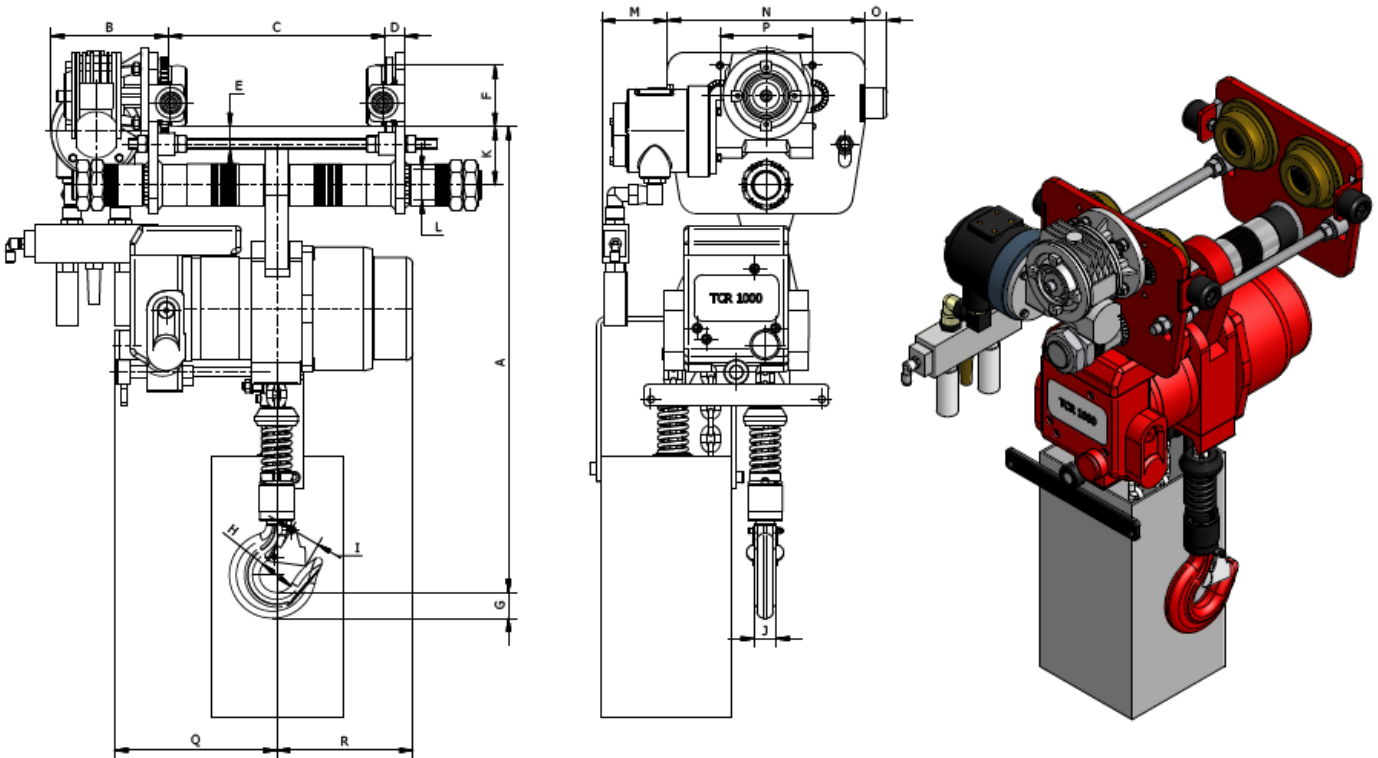

A	B	C	D	E	FØ	G	H	I	J	K	L	M	N	O	P	Q	R
~534	~135	TBC	22	27	70	29	40	29	25	67	35	75	227	25	106	186	156

All measurements are in mm

Drawing For illustration purposes only. Not drawn to scale.